

IN-GROUND WP1500 / 750SK

In-ground packaged sewage & waste water pump station
With Single pump. (Option for Twin pump available on request)

APPLICATION

The Wallace In-Ground WP1500 / 750SK pump station is typically designed for pumping sewage & waste water from a dwelling where facilities generating waste water are below conventional council sewer line and with 24 hour storage requirement is necessary.

DESIGN FEATURES

- New Zealand designed & manufactured PE pump chamber suitable for storage of domestic sewage and wastewater.
- Suitable for installation underground with normal soil conditions **without high water table.**
- **Not recommended for installation under concrete drive-ways** or any other **trafficable surface.** Access to tank lid must be available for maintenance.
- The geometric shape allows for maximum strength under compression while also offering the Advantage of anti-floatation
- Pump station is supplied complete with selected pump, Non Return Valve, Isolating Valve, Union, Float switch/s all installed & with 100mm Inlet & 50mm outlet connections provided on chamber for ease of connections to pipes. Pump power cable and high level alarm cable are taken out from the top of the tank via suitable gland to be connected to control panel at site.
- Motor Protection Control panel with built in High Level Alarm activation & volts free contacts for remote monitoring, is supplied loose to be installed in weatherproof location & connected to power & HL cables thus providing motor protection from Overload, Underload & Short circuit conditions. Optional water shut off system in case of HL activation is available as extra

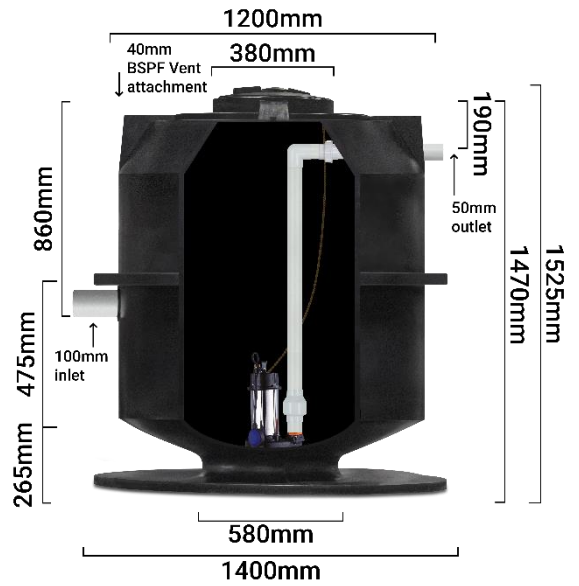

TECHNICAL DATA

Tank Volume (Litres)	1400 approx.	Weight (Pump)	22Kg
Dimensions (mm)	1400 Ø X 1525	Max Head (m)	8 Including Sump Depth
Inspect Hatch (mm)	380 Ø	Control Panel / H L Alarm	Motor Protection & HL activation with Audio/Visual
Total Weight (Kg)	125 Kg approx.	Inlet	100mm PVC class D
Pump (Type)	W-750SK	Discharge	50mm PVC class D
Motor Rating	0.75KW, 230V, 7A	Valves	50mm non return & isolating

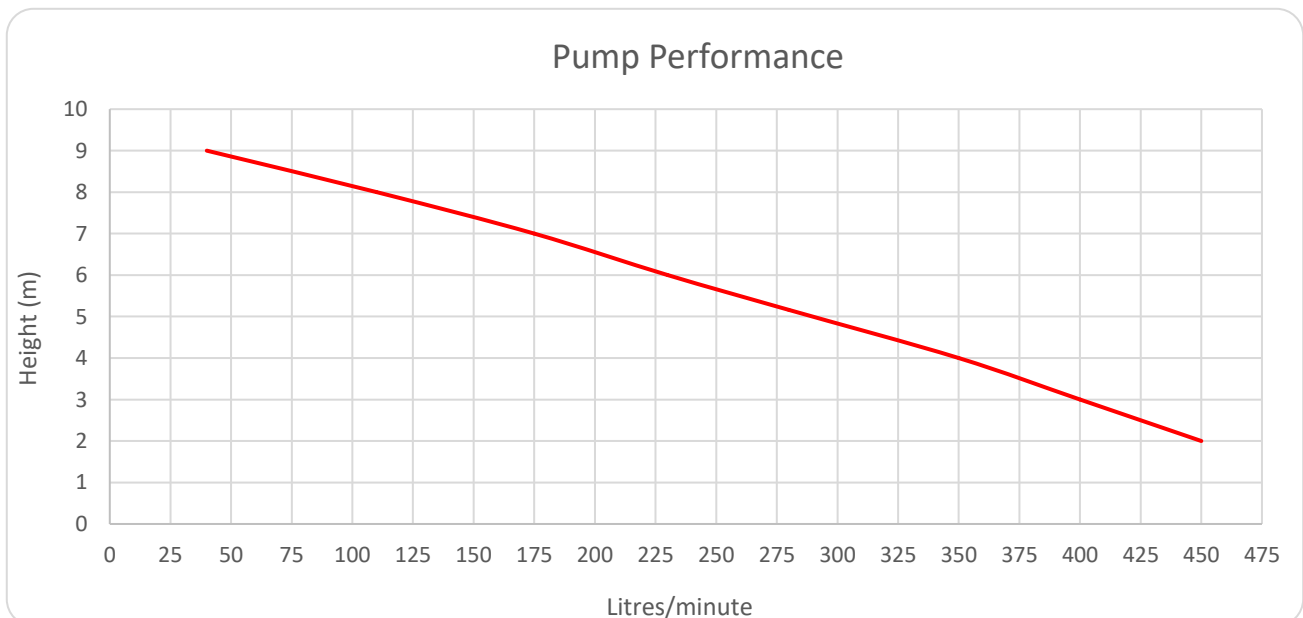

IN-GROUND WP1500 / 750SV

In-ground packaged sewage & waste water pump station
With Single pump. (Option for Twin pump available on request)

APPLICATION

The Wallace In-Ground WP1500 / 750SV pump station is typically designed for pumping sewage & waste water from a dwelling where facilities generating waste water are below conventional council sewer line and with 24 hour storage requirement is necessary.

DESIGN FEATURES

- New Zealand designed & manufactured PE pump chamber suitable for storage of domestic sewage and wastewater.
- Suitable for installation underground with normal soil conditions **without high water table.**
- **Not recommended for installation under concrete drive-ways** or any other **trafficable surface.** Access to tank lid must be available for maintenance.
- The geometric shape allows for maximum strength under compression while also offering the Advantage of anti-floatation
- Pump station is supplied complete with selected pump, Non Return Valve, Isolating Valve, Union, Float switch/s all installed & with 100mm Inlet & 50mm outlet connections provided on chamber for ease of connections to pipes. Pump power cable and high level alarm cable are taken out from the top of the tank via suitable gland to be connected to control panel at site.
- Motor Protection Control panel with built in High Level Alarm activation & volts free contacts for remote monitoring, is supplied loose to be installed in weatherproof location & connected to power & HL cables thus providing motor protection from Overload, Underload & Short circuit conditions. Optional water shut off system in case of HL activation is available as extra

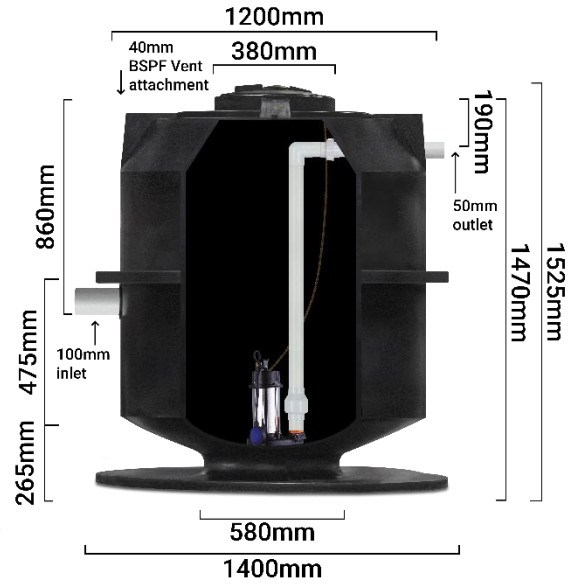

TECHNICAL DATA

Tank Volume (Litres)	1400 approx.	Weight (Pump)	22Kg
Dimensions (mm)	1400 Ø X 1525	Max Head (m)	9.5 Including Sump Depth
Inspect Hatch (mm)	380 Ø	Control Panel / H L Alarm	Motor Protection & HL activation with Audio/Visual
Total Weight (Kg)	125 Kg approx.	Inlet	100mm PVC class D
Pump (Type)	W-750SV	Discharge	50mm PVC class D
Motor Rating	0.75KW, 230V, 7A	Valves	50mm non return & isolating

Pump Performance

